

# SPECIFICATIONS

## P-8 OR FW-8

### Exterior Dimensions

33" Height  
23" Width  
30" Depth

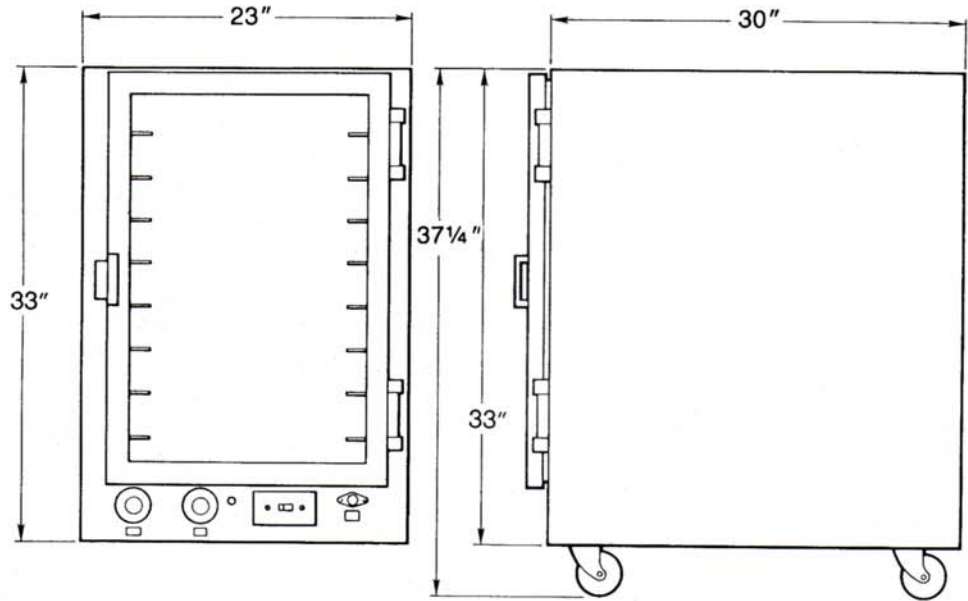

# ELECTRICAL

## P-8 or FW-8: 1550 watts

MODEL#	VOLTAGE AND PHASE	NEUTRAL	TOTAL LOAD(AMPS)	CONNECTION TYPE
P-8 FW-8	120-1-60	REQUIRED	13	6' POWER CORD

# WARRANTY

One Full Year on all parts from date of purchase

# SHIPPING

Approximately 115 lbs. F.O.B. Bradenton, Florida

**MODEL**  
**P-8 OR FW-8**  
**PROOFER FOR "FULL-SIZE PANS"**

